



Contact Details

Sydney (NSW)
120 Hume Highway
Lansvale 2166
Ph: (02) 9794 1111
Fax: (02) 9794 1199

Adelaide (SA)
89 Heaslip Road
Burton 5110
Ph: (08) 8280 2000
Fax: (08) 8280 8099

Brisbane (QLD)
86 Mudgee Street
Kingston 4114
Ph: (07) 3489 6200
Fax: (07) 3489 6299

Perth (WA)
75 Briggs Street
Carlisle 6101
Ph: (08) 9470 1800
Fax: (08) 9472 3802

Melbourne (VIC)
33 Remington Drive
Dandenong South 3175
Ph: (03) 9799 6888
Fax: (03) 9799 9688

Northern Territory (NT)
3 Adams Road (Cnr Beresford)
Yarrowonga NT 0830
Ph: (08) 8932 3733
Fax: (08) 8932 3799

EVOLUTION CAVITY SOFT CLOSER

Fitting Pack & Installation Instructions

www.humedoors.com.au

100% Australian Owned

EVOLUTION CAVITY SOFT CLOSER

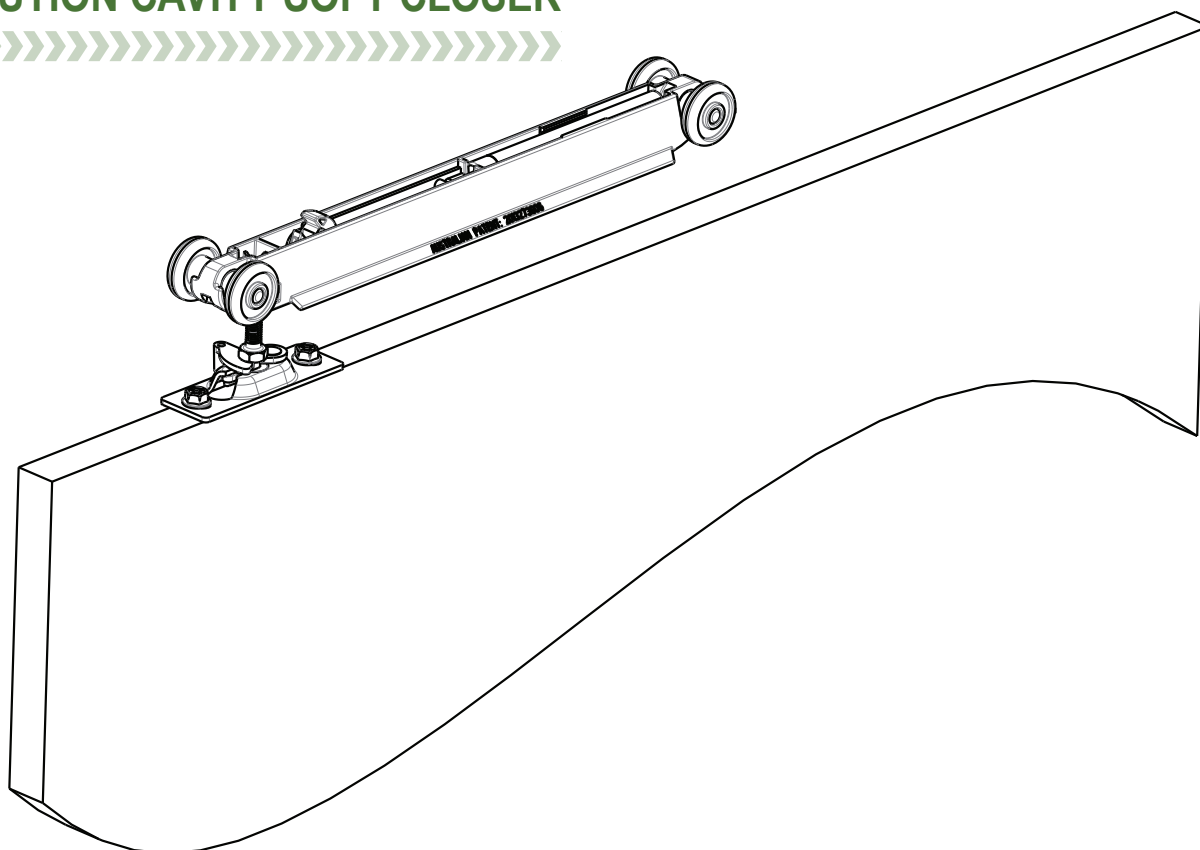

100% Australian Owned

www.humedoors.com.au



HUME SOFT CLOSE UNIT

HOW TO RETRO FIT TO HUME CAVITY UNIT

COMPONENTS SUPPLIED WITH SOFT CLOSE UNIT:

- 1 x Soft Close Cavity Roller
- 1 x Soft Close Strike Plate
- 4 x Screws
- 1 x Spanner
- 1 x Instruction Booklet

TOOLS REQUIRED



Tape Measure



Phillips Head Screw Driver



Cordless Drill Plus Drill & Driver bit



1. REMOVE DOOR FROM CAVITY UNIT

Remove the timber pelmet above the door opening, unclip the mounting plate lock tabs to disengage the front and back wheel assemblies.

Remove the door from the cavity unit, leaving only the rear wheel assembly in the track, the front wheel assembly is no longer required.

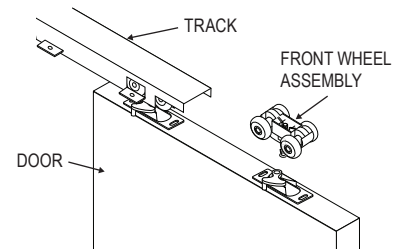

2. CHECK POSITION OF MOUNTING PLATE

IMPORTANT - Check the front of the mounting bracket is 80mm from the leading edge of the door, if not remove the mounting plate and using the drilling guide on the strike plate re-drill the door and fix the mounting plate in the correct position

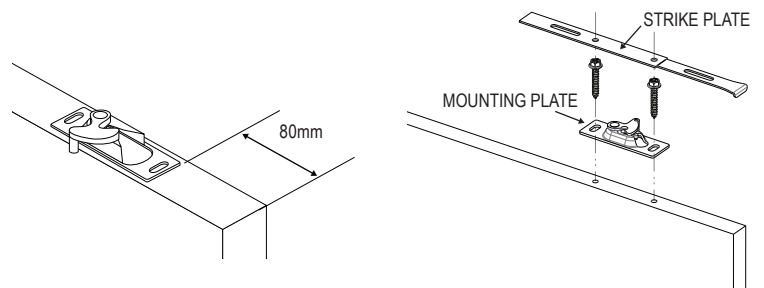

3. CHECK SPRING STRENGTH SETTING

The spring strength setting is factory set on the "B" position. This will suit the majority of doors.

For large or heavy doors move the spring to the "A" position.

For small or lightweight doors you can move the spring to the "C" position.

Moving the position will change the closing speed and resistance when opening the door.

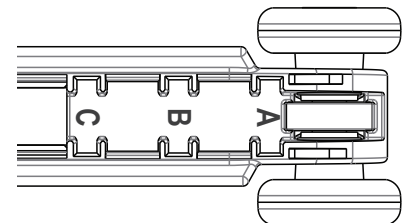

4. INSTALL THE SOFT CLOSE UNIT

Slide the soft close unit into the track and re-attach the door onto both the front and back mounting plates, adjust the door back to the original position using the spanner provided.

Inside the track, position the strike plate in line with the closing jamb, (the stamped arrow points toward the door). Fix using 2x self drilling screws into the middle of the slotted sections.

Slide the door toward the closing jamb to engage the soft unit. On older cavity units you may need to reverse the strike plate if the soft close does not engage.

To adjust the finished position, loosen the screws and move the strike plate forward or backward until the door rests against the closing jamb.

Fix the remaining self drilling screws into the end and centre holes to lock the strike plate in position, re attach the timber pelmet above the door opening.

